

S-TYPE

CLASS			
Classification	Lloyd's Register 100 A1		
Ice-Class	Finnish/ Swedish 1A		
PRINCIPAL DIMENSIONS			
Length over all	168,21	m	/173,18 m*
Breadth moulded	25,20	m	/ 25,30 m*
Height hold as SID	14,38	m	Hold 1: 11,88 m
Height lower hold as TWD	3,18 or 7,03 or 10,23	m	Hold 1: 4,63 m
Height tween deck as TWD	3,05 or 6,25 or 10,10	m	Hold 1: 6,25 m
Summer draft	10,74	m	
GT	Abt. 16.641		
NT	6.730		
DEADWEIGHT all told	21.400	mt	excl. TWD
	20.760	mt	incl. TWD
CAPACITY			
Grain - bale	840.250	cbft	/23.820 m ³
FLOOR SPACE			
Tank top	1.620	m ²	
Tween deck	1.834	m ²	
Weather deck	2.155	m ²	
AIR CHANGES (basis empty holds)			
Hold 0, 1, 2/3	Abt. 6 x , 20 x, 20 x		p/h
Dehumidifier	Yes		
CONTAINER INTAKE			
Total	1.134	TEU	
HATCHES			
Weather deck	No.0: 6,40 x 7,60	m	
	No.1: 25,60 x 17,80	m	/15,20 m
	No.2: 38,40 x 17,80	m	
	No.3: 32,00 x 20,40	m	
	Steel, end folding/rolling/lift away type		
Tween deck	No.1: 25,60 x 17,80	m	/15,20/10,10m
	No.2: 38,40 x 17,80	m	
	4,40 x 17,80	m	under cross beam
	No.3: 32,00 x 20,40	m	
Consisting: 16 steel pontoons:	1 of 6,37 x 15,12 m 2 of 3,17 x 17,72 m 1 of 4,20 x 17,72 m 2 of 6,37 x 10,02 m 6 of 6,37 x 17,72 m 4 of 6,37 x 20,32 m		
Bulkheads/ compartments	Removable pontoons for up to 14 compartments at TEU interval		
MAXIMUM LOAD			
Weather deck hatch covers	2,00	t/m ²	payload
Tweendeck hatch covers	Hatchway 1:	7,50	t/m ²
	Hatchway 2:	5,50	t/m ²
	Hatchway 3:	5,00	t/m ²
Tank top	20,00	t/m ²	
DECK CRANES			
Position	2 x port side (aft and mid), 1 x starboard (forward)		
Tons/reach	120 mt SWL/ 14 m 90 mt SWL/ 18,6 m 55 mt SWL/ 30 m		
SIDELoadERS			
Position	5 x starboard side		
Capacity	16 mt SWL		

These particulars are believed to be correct, but without guarantee, and they must not be used as basis for Charter Parties or contracts without explicit written authority.

For more information please contact amsterdam@spliethoff.com



2000 Schippersgracht, Singelgracht, Slottergracht, Snoekgracht, Spaarnegracht, Spiegelgracht, Scheldegracht*, Stadiongracht*

2001 Sluisgracht*, Spuigracht*

2004 Statengracht*

* = different in length and breadth

S-TYPE

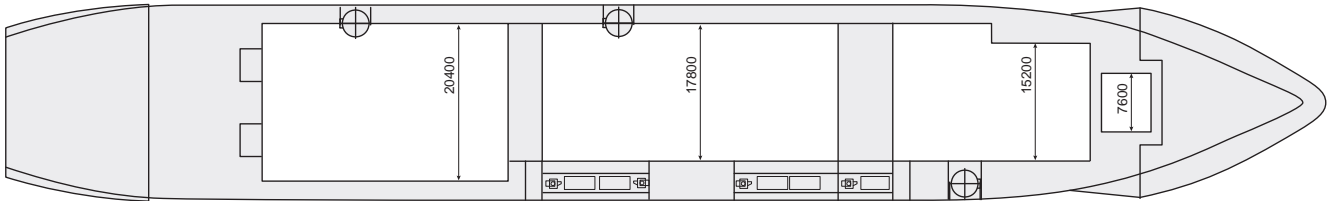
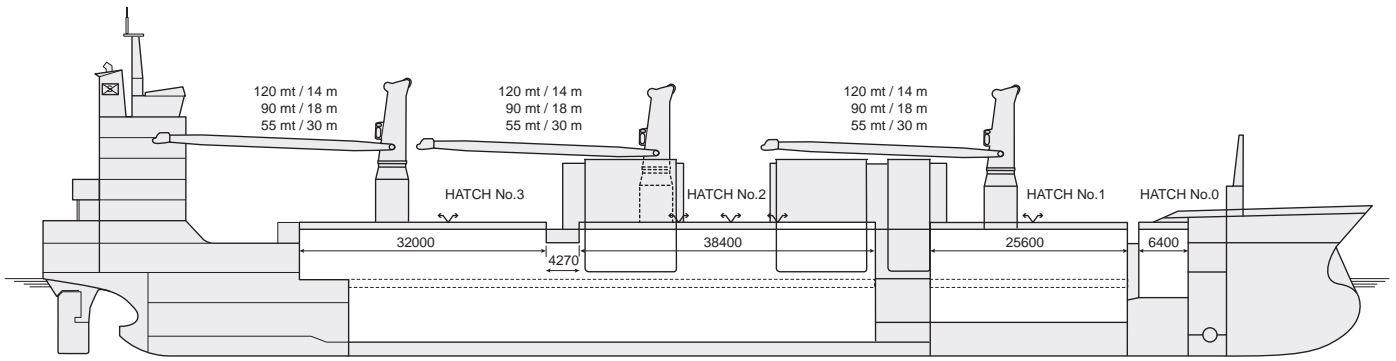

WEATHER DECK

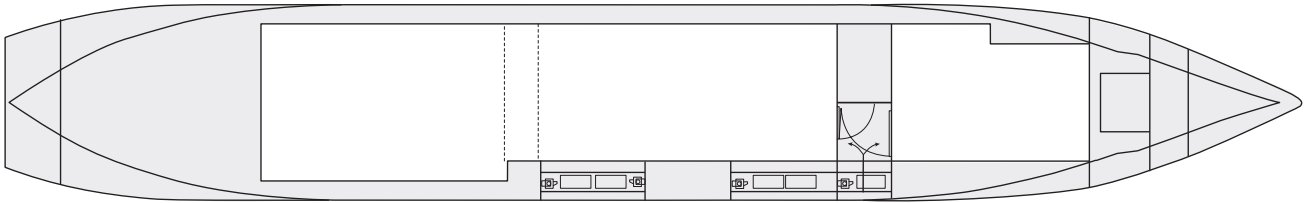

TWEEN DECK

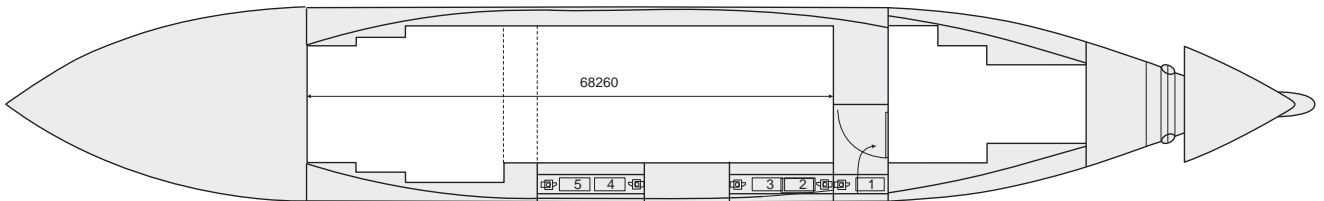

TANK TOP

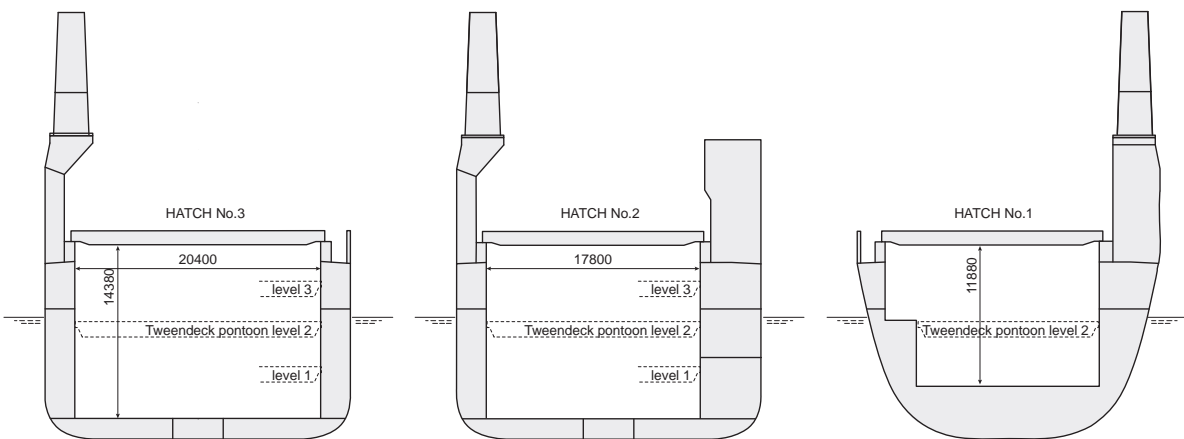

CROSS SECTION

